

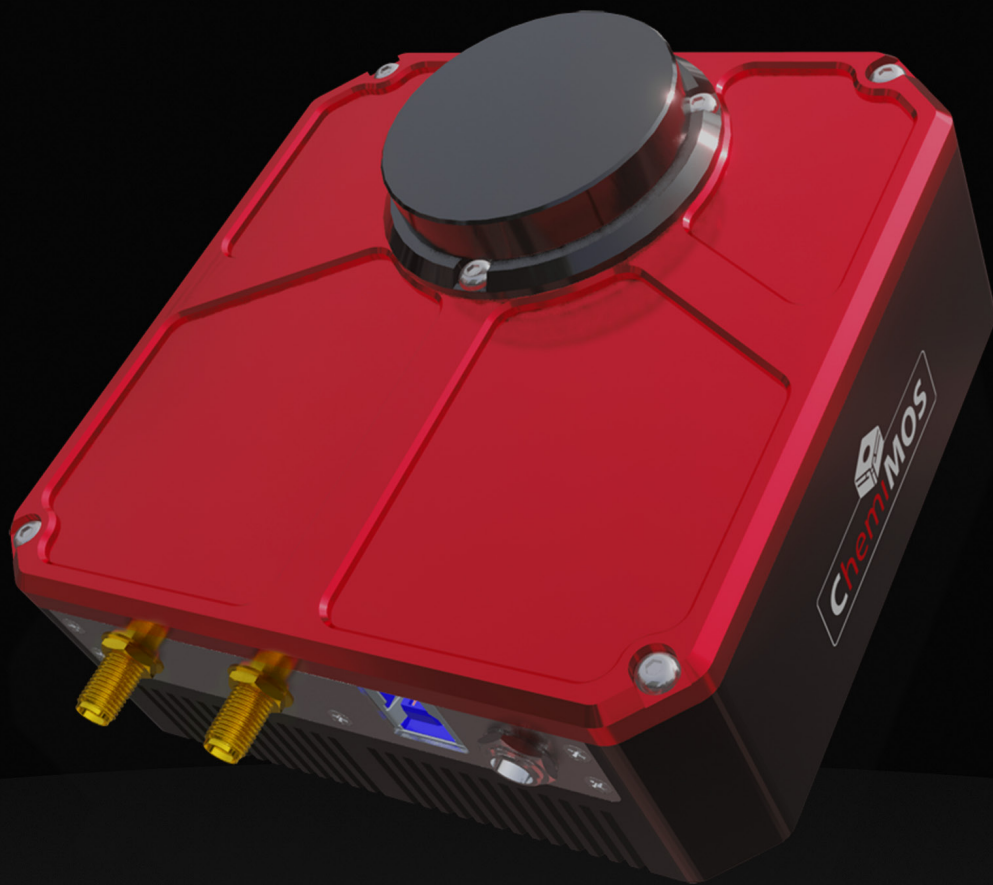

*Experts In Low Light Imaging*



# ChemiMOS Series



## ChemiMOS Overview

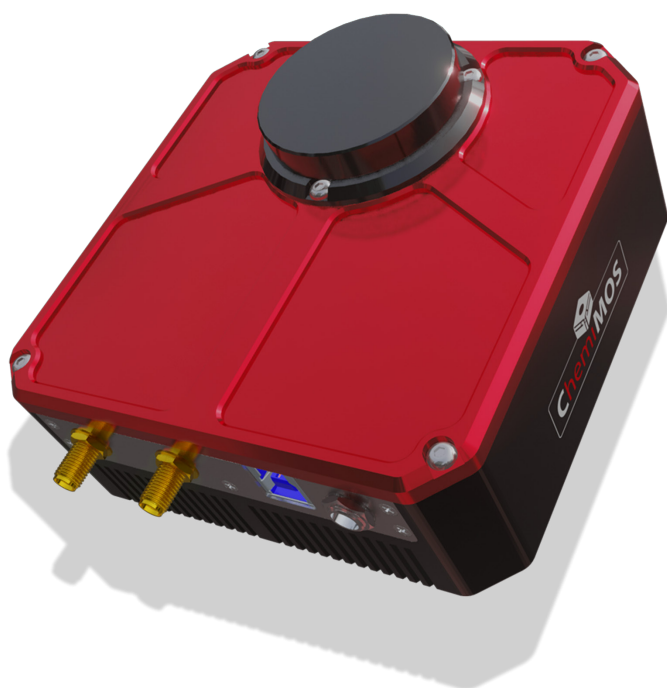

ChemiMOS is a cooled CMOS camera designed from the ground up to be ideally suited for integration into scientific systems requiring long exposure images. Hours of exposure time has previously only been available with CCD technology, but is now possible with ChemiMOS due to the zero-amp glow and low-noise design. This latest generation of CMOS technology will be available for the foreseeable future, ensuring long-term, supply chain stability. Benefits include very low read noise and deep pixel full well, allowing for unprecedented dynamic range.

Cooling is optimised to minimise the dark current, without the need for extreme temperatures, which could complicate the end user design. Calibration routines such as dark frame subtraction and off-camera image processing are included, meaning flexibility and transparency when operating the camera. There is no down time for recalibration as the sensor characteristics change over time.

## ChemiMOS Technical Specifications

### \*ChemiMOS 9.0 specifications

Image sensor	IMX 533 (latest generation Sony CMOS)
Resolution	3000 × 3000
Pixel size	3.76 $\mu\text{m}$
Read noise (High gain)	<1.5 $e^-$
Dark current noise (at -20°C)	0.0005 $e^-/p/s$
Set point cooling (at ambient of 20°C)	-20 °C
Full well capacity (Low gain)	>50,000 $e^-$
A/D converter	14 bit (With 16 bit image mode)
Frame rate	12fps
QE peak	>90%
Interface	USB 3.2 Gen1
Lens mount	C-Mount (can be customised)

Customised versions of ChemiMOS are also available with 26 MP, 60 MP, 102 MP and 150 MP variant of the sensors. Contact Atik Cameras for more information.

## ChemiMOS-9R Overview



With the discontinuation of the Sony CCD cameras, the ChemiMOS was designed from the ground up to be the perfect drop in replacement. With the higher QE, lower noise and better dynamic range the ChemiMOS cameras provide perfect replacement cameras.

If switching a camera in an existing system from the ICX694/ICX695 or ICX814/ICX815 the ChemiMOS R camera adds to this a perfect matching of sensor size as well. This negates the need for optics or lens changes making the camera switch a much quicker and cheaper proposition.

On top of the benefits of the standard ChemiMOS, the rectangular variant also provides a true 16bit ADC readout. For any long exposure, high dynamic range imaging, Atik Cameras has a well defined solution for your imaging needs.

## ChemiMOS-R Technical Specifications

### \*ChemiMOS-R 9.0 specifications

Image sensor	IMX 533 (latest generation Sony CMOS)
Resolution	3380 × 2704
Pixel size	3.76 μm
Read noise (High gain)	<1.5 e <sup>-</sup>
Dark current noise (at -20°C)	0.0005 e <sup>-</sup> /p/s
Set point cooling (at ambient of 20°C)	-20 °C
Full well capacity (Low gain)	>50,000 e <sup>-</sup>
A/D converter	16 bit
Frame rate	4fps
QE peak	>90%
Interface	USB 3.2 Gen1
Lens mount	C-Mount (can be customised)

\*Please note, all specifications are provisional figures, and subject to change.

# ChemiMOS-9F Overview



Leveraging the advantages and features of Chemimos and Chemimos R, we provide an off the self solution that is simple to integrate. By maintaining the filters between the sensor and the camera, we enable integrators to quickly devise a solution that offers both performance and cost benefits. Additional integration with optics can be provided upon request.

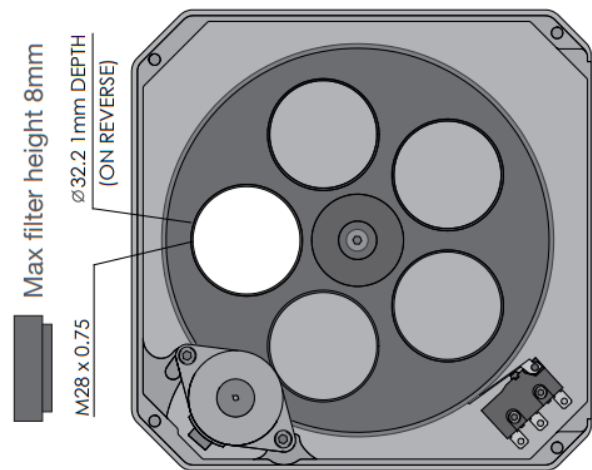

# ChemiMOS-9F Technical Specifications

## \*ChemiMOS 9 F specifications

Image sensor	IMX 533 (latest generation Sony CMOS)
Resolution	3000 × 3000
Pixel size	3.76 µm
Read noise (High gain)	<1.5 e <sup>-</sup>
Dark current noise (at -20°C)	0.0005 e <sup>-</sup> /p/s
Set point cooling (at ambient of 20°C)	-20 °C
Full well capacity (Low gain)	>50,000 e <sup>-</sup>
A/D converter	14 bit (With 16 bit image mode)
Frame rate	12fps
QE peak	>90%
Interface	USB 3.2 Gen1
Lens mount	C-Mount (can be customised)
Filter Wheel	Standard: 5 Position 32mm Aperature Optional: 6 Position 25mm Aperature

## ChemiMOS Variants

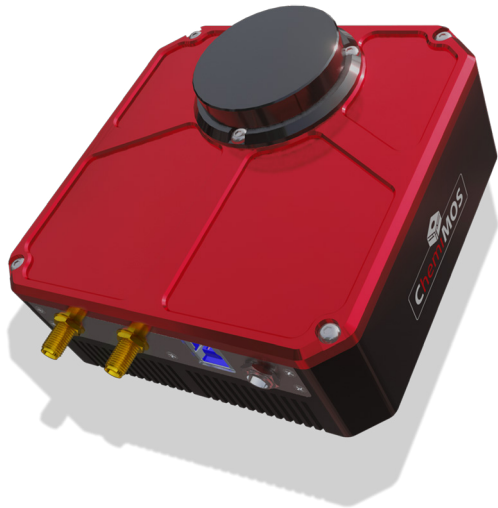

### Standard

Best pricing with performance better than CCD and other cooled CMOS sensors for the majority of applications.

### Deep Cooled

For the options when dark current or temperature stability is an absolute priority this version of ChemiMOS gives an extra 15 degrees cooling delta in the same housing format.



### Rectangular Sensor

Using the same performance benefits as the standard ChemiMOS but with a sensor designed to exactly match the physical size of the previous CCD cameras meaning no changes in optics are needed.



### Filter Wheel

In light of the discontinuation of CCDs, there is an immediate requirement for system integrators to swiftly incorporate substitute technologies. Utilizing our vast expertise in the production and design of cameras and filter wheels, we combine these two elements to minimize integration time and deliver a superior products that fit within a reasonable budget.

## Across all three options

- No amp glow and exceptionally low dark current ( $0.0005 \text{ e-}/\text{p/s}$ )
- Very low read noise modes ( $1.2\text{e-}$ ) allowing CMOS binning whilst still keeping low added read noise
- High dynamic range ( $>50\text{k e-}$  single pixel) with 16 bit imaging modes
- Advanced features to extend dynamic range further
- Atik Cameras European manufactured proven chamber quality

## Integration

Our cameras run from a standard SDK library that is fully transferable between PC, Mac and Linux operating systems. With full example files and a dedicated support team, integrating and supporting ChemiMOS in your system is made easy.

## OEM Supply

Atik Cameras is a reliable OEM supplier with over 15 years' experience in this field. Since moving to a larger state-of-the-art facility in January 2020 to increase production capacity, Atik Cameras have shipped over 10,000 cameras per year to integrators all around the world. With industry leading quality standards and robust batch tracking, you can be sure that cameras shipped from our European production facility in Portugal, will be of the highest quality and will work for your customers for many years to come.

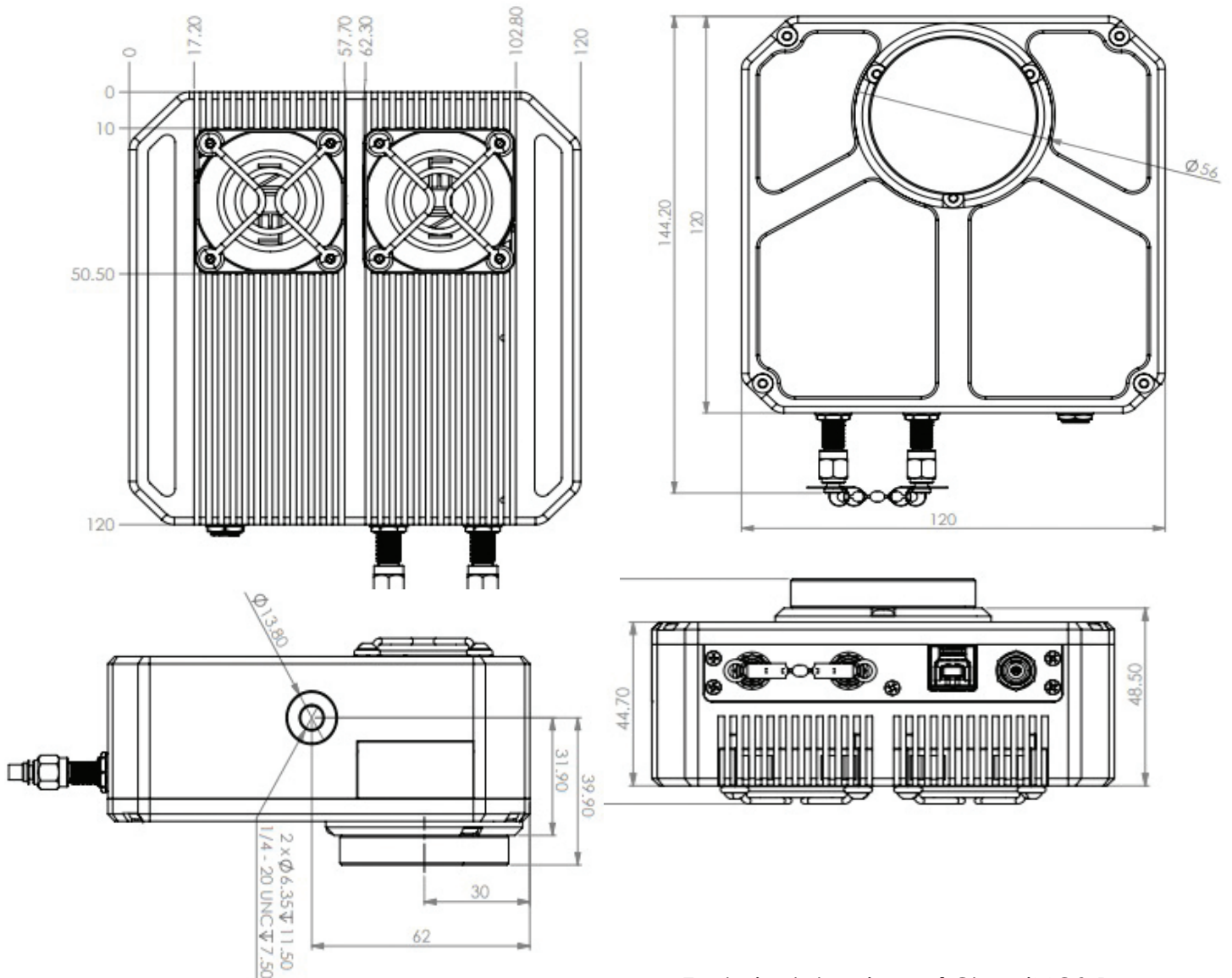

Technical drawings of ChemiMOS-R are available upon request.

## Atik Cameras

Atik Cameras has been dedicated to delivering cost-effective high-performance products for over 20 years. We believe in a collaborative approach, working closely with your engineers and integrators to meet any OEM application needs precisely.

Our products are designed in the UK and manufactured in Portugal at our ISO 9001-accredited facility. All our standard cameras can be supplied as board-level cameras and modified to suit your specific requirements. Our cameras are suited to multiple OEM applications with some of the most common being: Gel Documentation, Neutron and X Ray Imaging, and Fluorescence Microscopy.

Our flexible design philosophy allows us to adapt or build a camera that suits your specific requirements. Throughout this process, if a product is not readily available, our R&D team will liaise with you at every step of the way to ensure that your exact camera requirements are met.

## OEM Supply

With over 20 years' experience in this field, Atik Cameras thrives in providing custom OEM solutions. Since moving to a larger state-of-the-art facility in January 2020, Atik Cameras has shipped more than 30,000 cameras to integrators around the world.

Having industry leading quality standards and robust batch tracking, we can ensure that cameras shipped from our European production facility in Portugal will be of the highest quality and will perform well for your customers for many years to come.

## Tailored Solutions

We use our extensive experience in camera development for OEM applications, to provide the option of bespoke cameras that are made specifically for you and your requirements through our approach of collaborative customisation.

Any of our standard cameras can be altered, from a simple software or mechanical change, up to a completely new and novel design so that the end result is optimal for your application.

Once we agree on the specifications, we will further work with you to make integration of our

camera in your system as transparent as possible by adapting our SDK and software whether the camera is completely bespoke, customised or the base design.

## Applications

- **Chemiluminescence**
- **Gel Documentation**
- **Fluorescence Microscopy**
- **Neutron Imaging**
- **PCR and qPCR**
- **Spectroscopy**
- **Fluorescence Inspection**
- **Ophthalmology**
- **Space Domain Awareness**
- **Astrophotography**
- **Your Application**

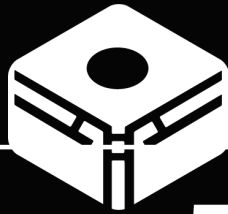

# ChemimOS



**Atik Cameras**

44 (0)1603 740397

[sales@atik-cameras.com](mailto:sales@atik-cameras.com)

[atik-cameras.com](http://atik-cameras.com)